

Original operating instructions

TOX[®] UDI Module

craft



Table of contents

1	Important information	
1.1	Legal note	5
1.2	Exclusion of liability.....	5
1.3	Conformity	5
1.4	Validity of the document	6
1.4.1	Content and target group.....	6
1.4.2	Other applicable documents.....	6
1.5	Gender note.....	6
1.6	Displays in the document.....	7
1.6.1	Display of warnings.....	7
1.6.2	Display of general notes	8
1.6.3	Highlighting of texts and images.....	8
1.7	Contact and source of supply	9
2	Safety	
2.1	Basic safety requirements	10
2.2	Organizational measures.....	10
2.2.1	Safety requirements for the operating company.....	10
2.2.2	Selection and qualifications of personnel	11
2.3	Fundamental hazard potential	12
2.3.1	Electrical hazards	12
2.4	Special types of risks	13
2.4.1	Electrical energy	13
3	About this product	
3.1	Intended use	14
3.1.1	Safe and correct operation	14
3.1.2	Foreseeable misuse	14
3.1.3	Substances harmful to the wetting properties of lacquers (LABS)	15
3.2	Product overview and function description	15
3.2.1	Product overview	15

Draft

4	Technical data	
4.1	Type sheet and data sheet	17
4.2	Connections of TOX® UDI Module	17
4.2.1	Supply voltage of TOX® UDI Module	17
4.2.2	Connecting line	17
5	Transport and storage	
5.1	Temporary storages.....	18
5.2	Dispatch for repair	18
6	Installation	
6.1	Safety during installation.....	19
6.2	Requirements for installation	20
6.2.1	Set-up location.....	20
6.3	Installation of TOX® UDI Module.....	22
6.3.1	Installation of TOX® UDI Module.....	22
6.3.2	Grounding connection.....	23
6.3.3	Installing connections	25
7	Software	
7.1	Parameterizing, Visualizing, Operating.....	28
7.2	Operating system settings	28
7.2.1	Post-Installation-Script.....	28
7.2.2	Operating system settings	29
7.3	Operation as UDI panel / UDI module	40
7.3.1	Basic settings screen.....	40
7.3.2	Remote maintenance (option)	41
7.3.3	Establishing VNC connection	43
8	Maintenance	
8.1	Requirements for maintenance and cleaning	44
8.2	Update TOX® Software	44

Draft

9	Disassembly and Disposal	
9.1	Disposal	46
10	Appendices	
10.1	Declaration of conformity	47
	Index	

Draft

1 Important information

1.1 Legal note

All rights reserved.

Operating instructions, manuals, technical descriptions and software published by TOX® PRESSOTECHNIK GmbH & Co. KG ("TOX® PRESSOTECHNIK") are copyright and must not be reproduced, distributed and/or otherwise processed or edited (e.g. by copying, microfilming, translation, transmission in any electronic medium or machine-readable form). Any use - including of extracts - contrary to this condition is prohibited without approval in writing by TOX® PRESSOTECHNIK and may be subject to criminal and civil legal sanctions.

If this manual refers to goods and/or services of third parties, this is for example only or is a recommendation by TOX® PRESSOTECHNIK.

TOX® PRESSOTECHNIK does not accept any liability or warranty/guarantee with reference to the selection, specifications and/or usability of these goods and services. The use and/or representation of trademarked brands that do not belong to TOX® PRESSOTECHNIK are for information only; all rights remain the property of the owner of the trademarked brand.

Operating instructions, manuals, technical descriptions and software are originally compiled in German.

1.2 Exclusion of liability

TOX® PRESSOTECHNIK has checked the contents of this publication to ensure that it conforms to the technical properties and specifications of the products or plant and the description of the software. However, discrepancies may still be present, so we cannot guarantee complete accuracy. The supplier documentation included with the system documentation is an exception.

However, the information in this publication is checked regularly and any required corrections are included in subsequent editions. We are grateful for any corrections and suggestions for improvement. TOX® PRESSOTECHNIK reserves the right to revise the technical specifications of the products or plant and/or the software or documentation without prior notice.

1.3 Conformity

The product is compliant with EU guidelines.

See separate Declaration of conformity or installation declaration.

Draft

1.4 Validity of the document

1.4.1 Content and target group

This manual contains information and instructions for the safe operation and safe maintenance or servicing of the product.

- All information in this manual is up to date at the time of print. TOX® PRESSOTECHNIK reserves the right to make technical changes that improve the system or increase the standard of safety.
- The information is intended for the operating company as well as operating and service personnel.

1.4.2 Other applicable documents

In addition to the available manual, further documents can be supplied. These documents must also be complied with. Other applicable documents can be, for example:

- additional operating manuals (e.g. of components or of a whole system)
- Supplier documentation
- Instructions, such as software manual, etc.
- Technical data sheets
- Safety data sheets
- Data sheets
- Schematics

1.5 Gender note

In order to enhance readability, references to persons that also relate to all sexes are normally only stated in the usual form in German or in the corresponding translated language in this manual, thus e.g. "operator" (singular) for male or female, or "operators" (plural) for male or female". This should in no way convey any gender discrimination or any violation of the principle of equality, however.

1.6 Displays in the document

1.6.1 Display of warnings

Warning signs indicate potential dangers and describe protective measures. Warning signs precede the instructions for which they are applicable.

Warning signs concerning personal injuries

DANGER

Identifies an immediate danger!

Death or severe injuries will occur if appropriate safety measures are not taken.

→ Measures for remedial action and protection.

WARNING

Identifies a potentially dangerous situation!

Death or serious injury may occur if appropriate safety measures are not taken.

→ Measures for remedial action and protection.

CAUTION

Identifies a potentially dangerous situation!

Injury may occur if appropriate safety measures are not taken.

→ Measures for remedial action and protection.

Warning signs indicating potential damage

NOTE

Identifies a potentially dangerous situation!

Property damage may occur if appropriate safety measures are not taken.

→ Measures for remedial action and protection.

1.6.2 Display of general notes

General notes show information on the product or the described action steps.



Identifies important information and tips for users.

1.6.3 Highlighting of texts and images

The highlighting of texts facilitates orientation in the document.

✓ Identifies prerequisites that must be followed.

1. Action step 1

2. Action step 2: identifies an action step in an operating sequence that must be followed to ensure trouble-free operation.

▷ Identifies the result of an action.

▶ Identifies the result of a complete action.

➔ Identifies a single action step or several action steps that are not in an operating sequence.

The highlighting of operating elements and software objects in texts facilitates distinction and orientation.

- <In square brackets> identifies operating elements, such as buttons, levers and (valves) stopcocks.
- "with quotation marks" identifies software display panels, such as windows, messages, display panels and values.
- **In bold** identifies software buttons, such as buttons, sliders, checkboxes and menus.
- **In bold** identifies input fields for entering text and/or numerical values.

Draft

1.7 Contact and source of supply

Only use original spare parts or spare parts approved by TOX® PRESSOTECHNIK.

TOX® PRESSOTECHNIK GmbH & Co. KG

Riedstraße 4

88250 Weingarten / Germany

Tel. +49 (0) 751/5007-767

E-Mail: info@tox-de.com

For additional information and forms see

www.tox.com

Draft

2 Safety

2.1 Basic safety requirements

The product is state of the art. However, operation of the product may involve danger to life and limb for the user or third parties or damage to the plant and other property.

For this reason the following basic safety requirements will apply:

- Read the operating manual and observe all safety requirements and warnings.
- Operate the product only as specified and only if it is in perfect technical condition.
- Remedy any faults in the product or the plant immediately.

2.2 Organizational measures

2.2.1 Safety requirements for the operating company

The operating company is responsible for compliance with the following safety requirements:

- The operating manual must always be kept available at the operation site of the product. Ensure that the information is always complete and in legible form.
- In addition to the operating manual, the generally valid legal and other binding rules and regulations must be provided for the following content and all personnel must be trained accordingly:
 - Work safety
 - Accident prevention
 - Working with hazardous substances
 - First aid
 - Environmental protection
 - Traffic safety
 - Hygiene
- The requirements and contents of the operating manual must be supplemented by existing national regulations (e.g. for prevention of accidents and for environmental protection).
- Instructions for special operating features (e.g. work organization, work processes, appointed personnel) and supervisory and reporting obligations must be added to the operating manual.

Draft

- Take action to ensure safe operation and make sure that the product is maintained in a functional condition.
- Only allow authorized persons access to the product.
- Ensure that all personnel work with awareness of safety and potential dangers with reference to the information in the operating manual.
- Provide personal protective equipment.
- Maintain all safety and information on dangers regarding the product complete and in legible condition and replace as required.
- Do not make any changes, carry out attachments or conversions to the product without the written approval of TOX® PRESSOTECHNIK. Action contrary to the above will not be covered by the warranty or the operating approval.
- Make sure that the annual safety inspections are carried out and documented by an expert.

2.2.2 Selection and qualifications of personnel

The following safety requirements are applicable for the selection and qualifications of personnel:

- Only appoint persons to work on the plant who have read and understood the operating manual, and in particular, the safety instructions before starting work. This is particularly important for persons who only work on the plant occasionally, e.g. for maintenance work.
- Only allow persons appointed and authorized for this work access to the plant.
- Only appoint reliable and trained or instructed personnel.
- Only appoint persons to work in the danger zone of the plant who can perceive and understand visual and acoustic indications of danger (e.g. visual and acoustic signals).
- Ensure that assembly and installation work and the initial commissioning are performed exclusively by qualified personnel who have been trained and authorized by TOX® PRESSOTECHNIK.
- Maintenance and repairs must be performed by qualified and trained personnel only.
- Ensure that personnel who are being trained, instructed or are in an apprenticeship can only work on the plant under the supervision of an experienced person.
- Have work on electrical equipment performed only by electricians or trained persons under the direction and supervision of an electrician in accordance with the electrotechnical regulations.

Draft

2.3 Fundamental hazard potential

Fundamental hazard potentials exist. The specified examples draw attention to known hazardous situations, but are not complete and do not in any way provide safety and risk awareness action in all situations.

2.3.1 Electrical hazards

Attention should be paid to electrical hazards particularly inside the components in the area of all assemblies of the control system and motors of the installation.

The following basically applies:

- Have work on electrical equipment performed only by electricians or trained persons under the direction and supervision of an electrician in accordance with the electrotechnical regulations.
- Always keep the control box and/or terminal box closed.
- Before commencing work on electrical equipment, switch off the main switch of the system and secure it against being switched back on inadvertently.
- Pay attention to the dissipation of residual energy from the control system of the servomotors.
- Make sure that the components are disconnected from the power supply when carrying out the work.

Draft

2.4 Special types of risks

2.4.1 Electrical energy

The following safety requirements must be observed for all work on electrical equipment:

- Have work on electrical equipment performed only by electricians or trained persons under the direction and supervision of an electrician in accordance with the electrotechnical regulations.
- Inspect electrical equipment regularly and repair any defects (e.g. loose connections, damaged cables etc.) immediately.
- Only authorized personnel are allowed access to the control box and/or terminal box as well as to all electrical supply units. Always keep the control box and/or terminal box closed.
- Before commencing work on electrical equipment, switch off the main switch of the system and secure it against being switched back on inadvertently. Make sure that the components are disconnected from the power supply when carrying out the work.

Draft

3 About this product

3.1 Intended use

The TOX® UDI Module is a fan-less Box-IPC for industrial installation of the switch cabinet on the basis of the ® Pentium™ Platform.

3.1.1 Safe and correct operation

Intended use includes the following conduct:

- Only operate with the components for which it is specified.
- Follow all instructions in this operating manual.
- Comply with the specified maintenance intervals and perform maintenance work correctly.
- Operate in compliance with the conditions of the technical data.
- Operation with fully assembled and functional safety devices.
- Activities may only be carried out by persons who are qualified or authorized for this purpose.

Any other use or application beyond this does not come under the scope of intended use.

3.1.2 Foreseeable misuse

Use contrary to intended use includes the following foreseeable misuse:

- Operation under conditions that deviate from the technical data.
- Operation without fully assembled and functional connections.
- Operation without fully assembled and functional safety devices.
- Modifications to the product without prior approval by TOX® PRESSOTECHNIK and the approving authority.
- Incorrect parameterization.
- Execution of activities by persons who are not qualified or authorized to do so.

The operating company is exclusively responsible for all personal injury and property damage resulting from non-intended use. Non-intended use will not be covered by the warranty or the operating approval.

Draft

3.1.3 Substances harmful to the wetting properties of lacquers (LABS)

No substances containing silicone, are knowingly processed and used.

3.2 Product overview and function description

3.2.1 Product overview

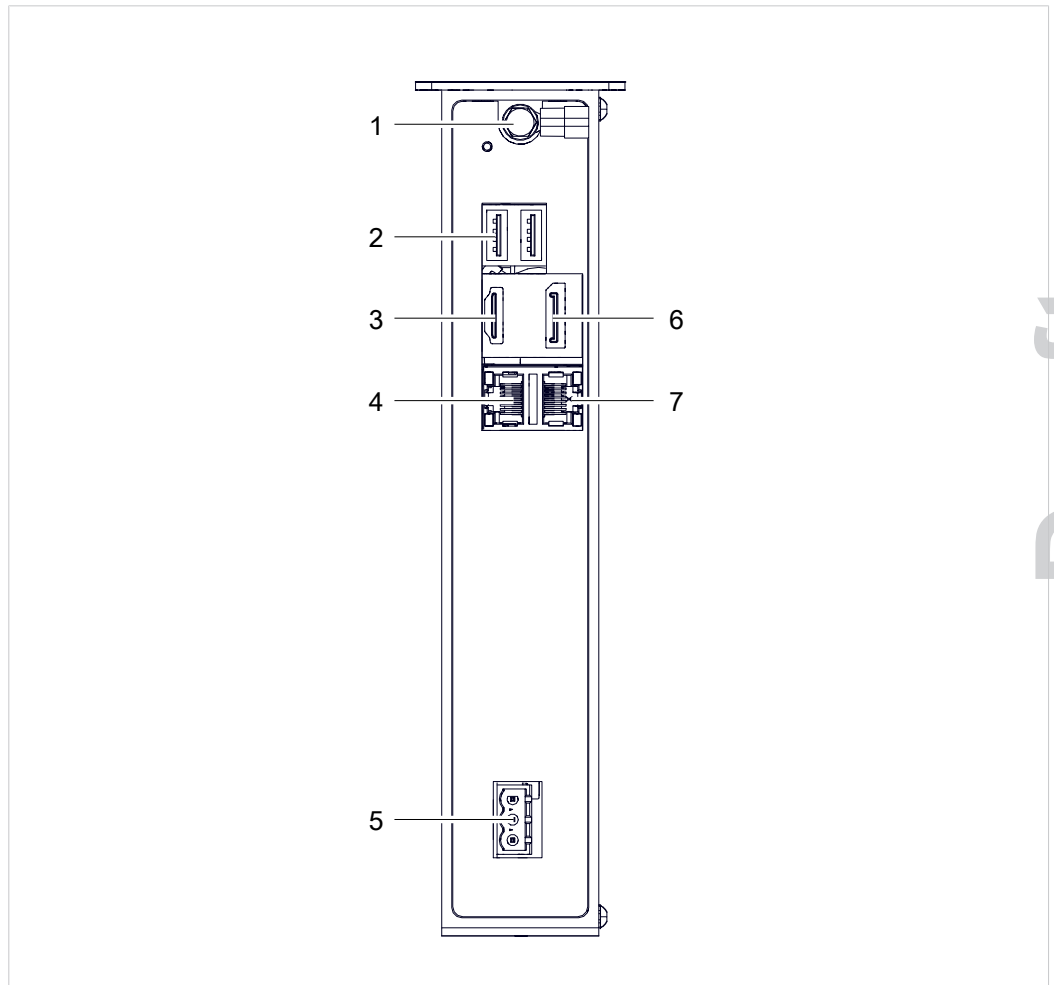

Fig. 1 Product overview

	Designation	Function
1	Grounding connection	Connection of the TOX® UDI Module to the grounding.
2	USB connection	For connecting, e.g. to a <ul style="list-style-type: none"> • USB stick • Keyboard
3	HDMI connection	For the connection of a monitor to the TOX® UDI Module.
4	Ethernet connection of TOX®	For the connection of the TOX® PowerModule.

Draft

	Designation	Function
5	Supply voltage	Connection of the TOX® UDI Module to the supply voltage.
6	Display port connection	For the connection of a monitor to the TOX® UDI Module.
7	Ethernet connection	Connection of the customer network.

Draft

4 Technical data

4.1 Type sheet and data sheet

For technical data and installation dimensions see data sheet.
www.tox.com

4.2 Connections of TOX® UDI Module

4.2.1 Supply voltage of TOX® UDI Module

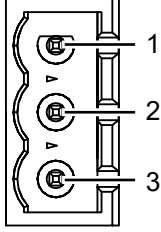
	Pin	Signal	Description
	1	24 V	DMS Supply voltage +24 VDC
	2	GND	Ground 0 VDC
	3	Remote detect	This pin is used to detect whether a panel is plugged in to operate the HMI Remote. In this case only one operation is still permitted via Remote.

4.2.2 Connecting line

Cables for 24 VDC	
Minimum bending radius	≥ 4-fold outside diameter of the cable
Cable cross section minimal	0.75 mm ² , AWG 19
Back-up fuse, maximum	B 6 A
Cable material	Copper (Cu)

Draft

5 Transport and storage

5.1 Temporary storages

- Use original packaging.
- Make sure that all electrical connections are covered to prevent dust ingress.
- Protect the display against sharp-edged objects e.g. due to cardboard or hard foam.
- Wrap the device, e.g. with a plastic bag.
- Store the device only in closed, dry, dust-free and dirt-free rooms at room temperature.
- Add drying agent to the packaging.

5.2 Dispatch for repair

To dispatch the product for repair to TOX® PRESSOTECHNIK, please proceed as follows:

- Fill in the "Accompanying repair form". This we supply in the service sector on our website or upon request via e-mail.
- Send us the completed form via e-mail.
- Then you will receive the shipping documents from us via e-mail.
- Send us the product with the shipping documents and a copy of the "Accompanying repair form".

For contact data see [Contact and source of supply, Page 9](#) or www.tox.com.

Draft

6 Installation

6.1 Safety during installation

The installation may only be carried out by trained and authorized personnel.

 **DANGER**

Electrical hazards in case of contact with live parts!

Electric shock, burns or death in case of contact with live parts!

- Have all work on the electrical equipment performed by an electrician.
- Disconnect power supply.
- Wait for residual energy to dissipate safely (at least 3 minutes).

Draft

6.2 Requirements for installation

6.2.1 Set-up location

The set-up location:

- Must be free from dust and dirt
- Must be a closed room
- Must have a firm, level floor
- Must have sufficient space and easy access to the system parts
- Prevent the spray of sparks
- The floor must have sufficient load bearing capacity for the weight of the system parts and stresses caused by movements
- The stability must be ensured



Information on technical data, operating conditions, etc. for the intended use can be found in type sheet or the product-specific data sheet and circuit diagram.

Installation spacings

NOTE

Installation of the TOX® UDI Module

For safe operation, the TOX® UDI Module must be installed without spacing on a smooth, closed, bare metal mounting plate.

NOTE

Power reduction due to accumulated heat

If the recommended minimum distances are not observed, the computing performance of the TOX® UDI Module may be reduced due to insufficient ventilation and the associated heat generation.

- Observe minimum distances.
- Ensure sufficient heat dissipation.

Draft

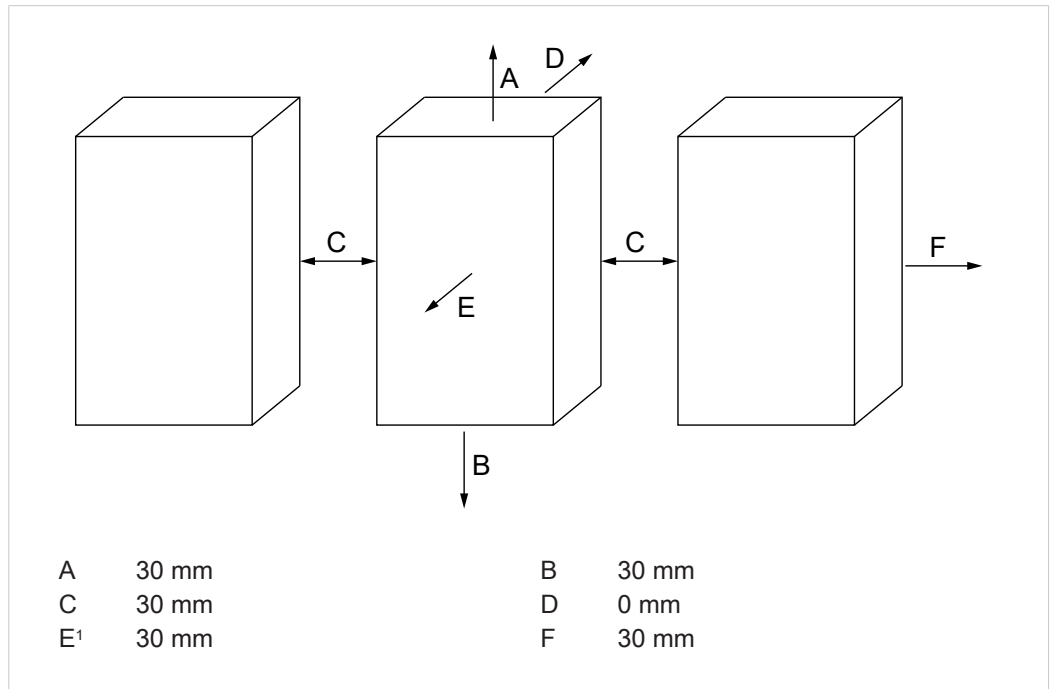

¹Distance to the upstream control elements in the switch cabinet door.

Draft

6.3 Installation of TOX® UDI Module

6.3.1 Installation of TOX® UDI Module

i Alignment of TOX® UDI Module

The TOX® UDI Module is to be installed vertical.

1. Drill necessary holes in the housing plate / wall.
For dimensions of the boreholes, see data sheet of the TOX® UDI Module.
2. Screw the fastening screws (e.g. M4 x 20) into the housing plate / wall.
3. Hang in and align the TOX® UDI Module.

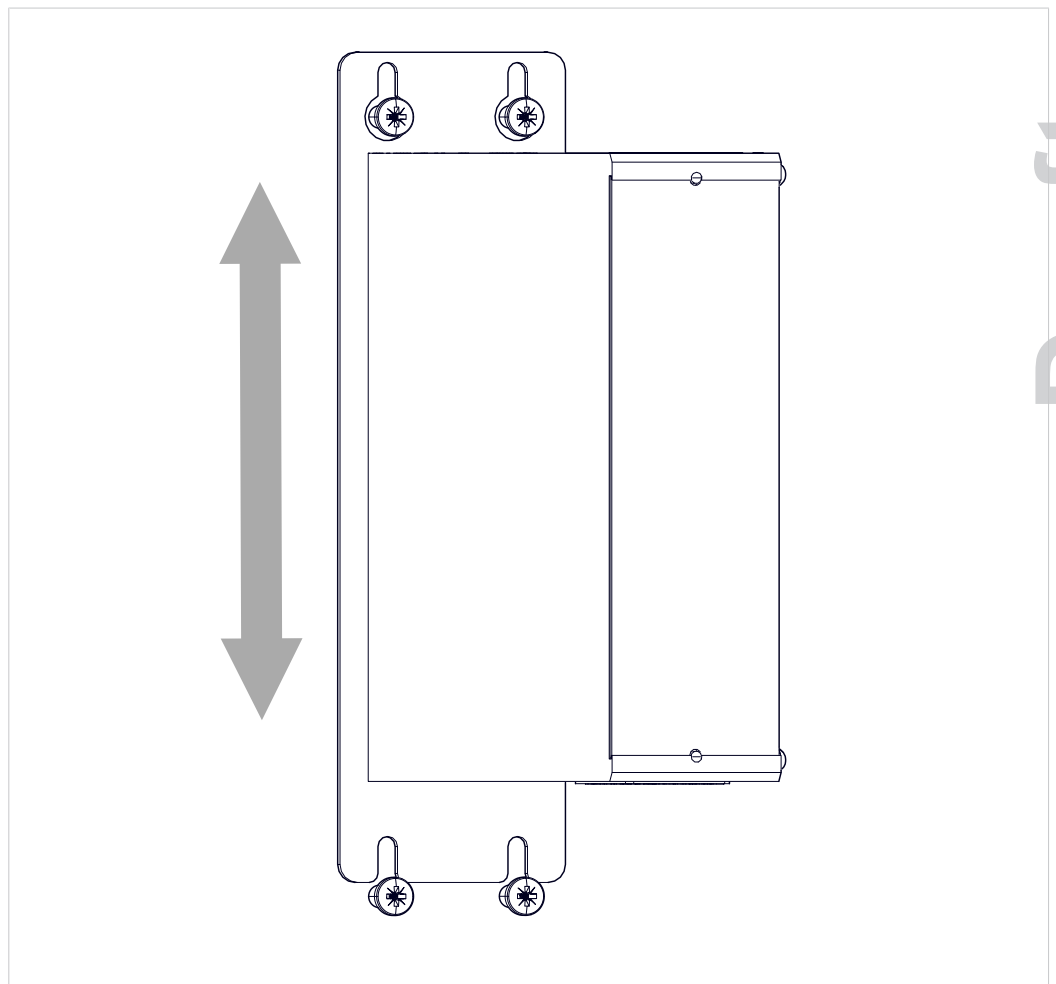

4. Tighten all fastening screws.

6.3.2 Grounding connection

NOTE

The grounding is not connected

Functionality of device not guaranteed.

- All grounding connections must be connected with a grounding point.
- A low-resistance grounding cable is to be used as connecting line.

A cable to the central grounding point of the switch cabinet or the plant must be installed on the grounding connection. The grounding connection is marked with a corresponding adhesive label.

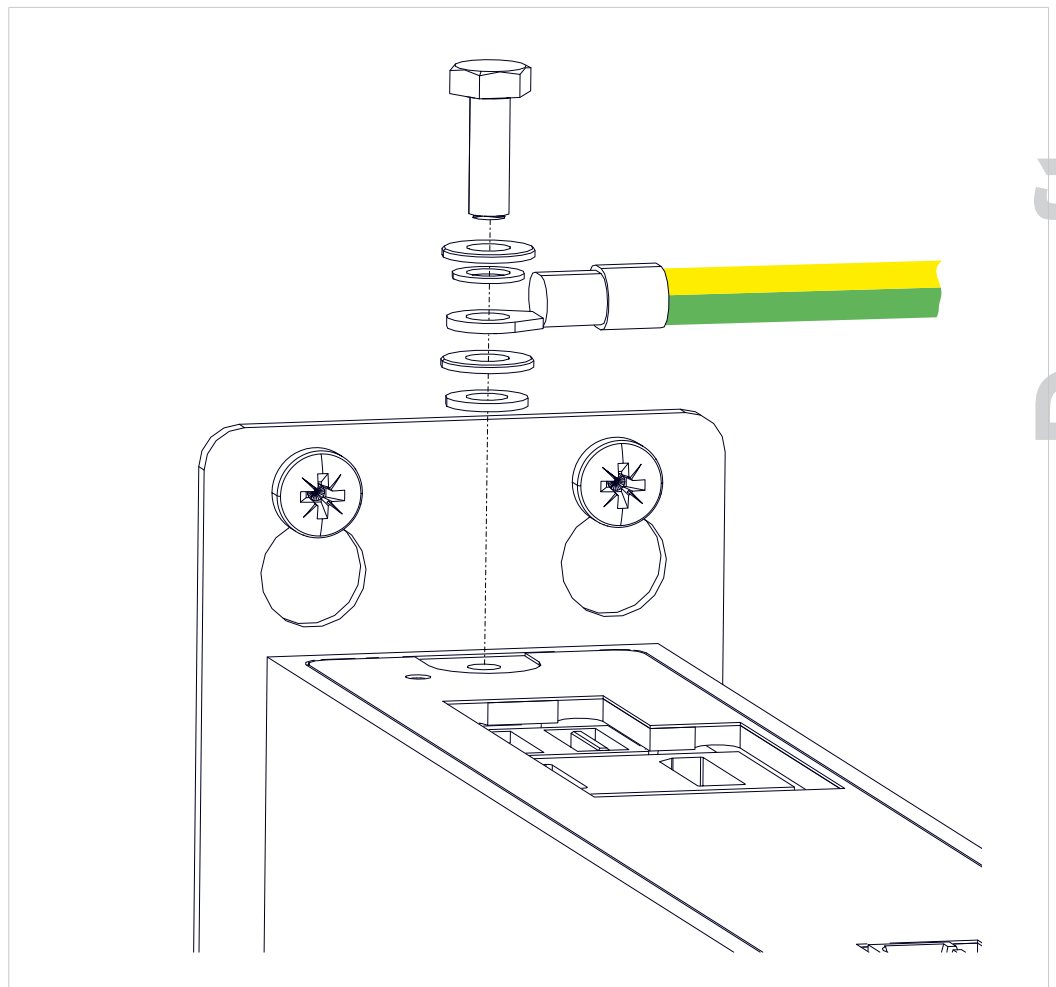

Fig. 2 Dismantling / installing the grounding connection

Draft

Insert a cable lug in the following order between the washers:

1. Contact washer
2. Washer
3. Cable lug
4. Washer
5. Locking washer
6. Hexagon screw M4

Draft

6.3.3 Installing connections

Connect TOX® UDI Module

 **DANGER**

Explosion

Death or serious injuries!

→ The USB connection must not be used in an explosive atmosphere.

 **CAUTION**

Faults of external power supply, signal or cables of periphery devices occur.

→ Create a proper grounding connection on the power adapter.

Draft

Supply voltage connection

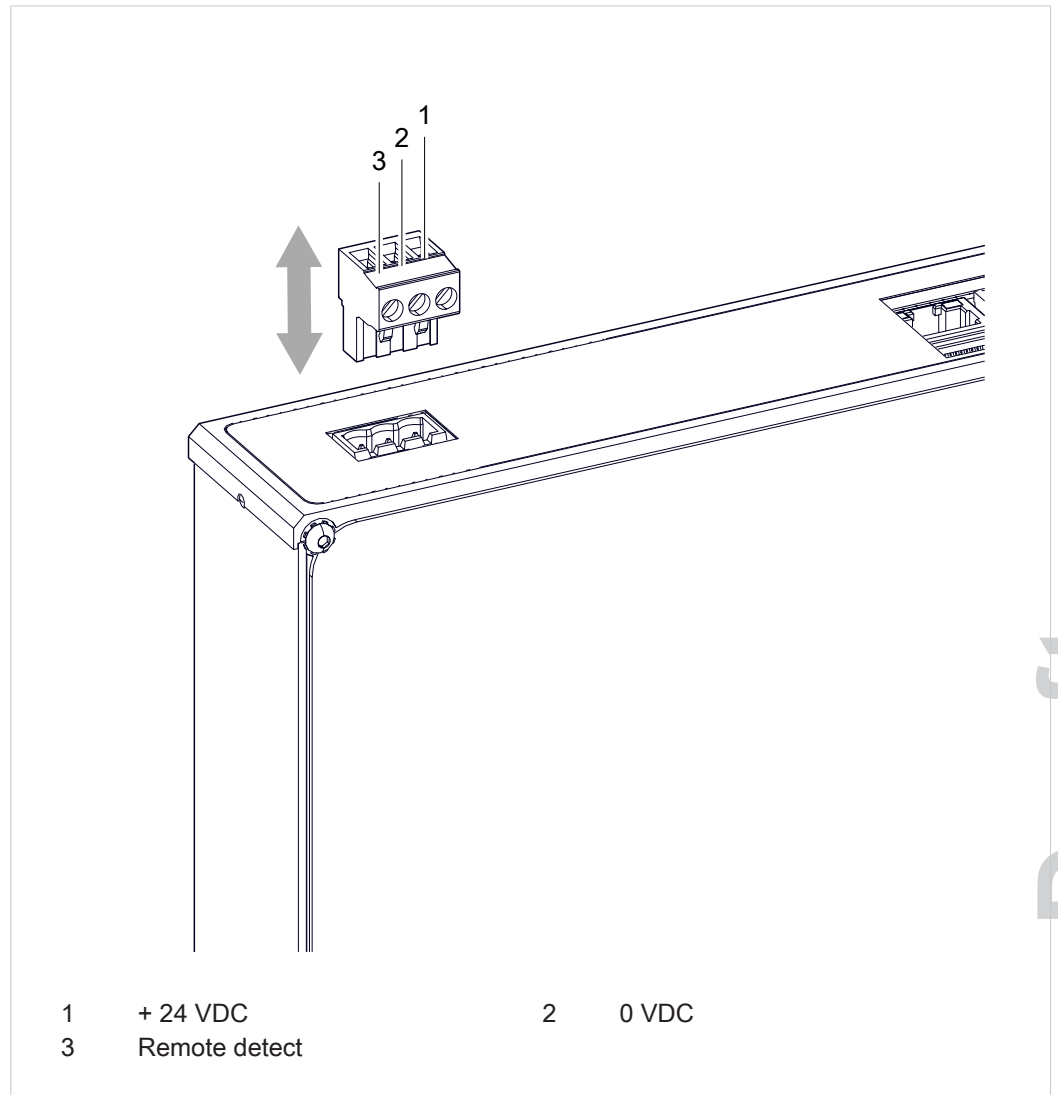

Fig. 3 Supply voltage connection

✓ Cross-section of wires from 0.75 mm² to 1.5 mm²

1. Strip wires to 7 mm.
2. Insert the wires into the connection contacts of the plug connector.
3. Tighten the screw contacts with a screwdriver.
 - ▷ Tightening torque 0.5 Nm.

Draft

Connection of customer network

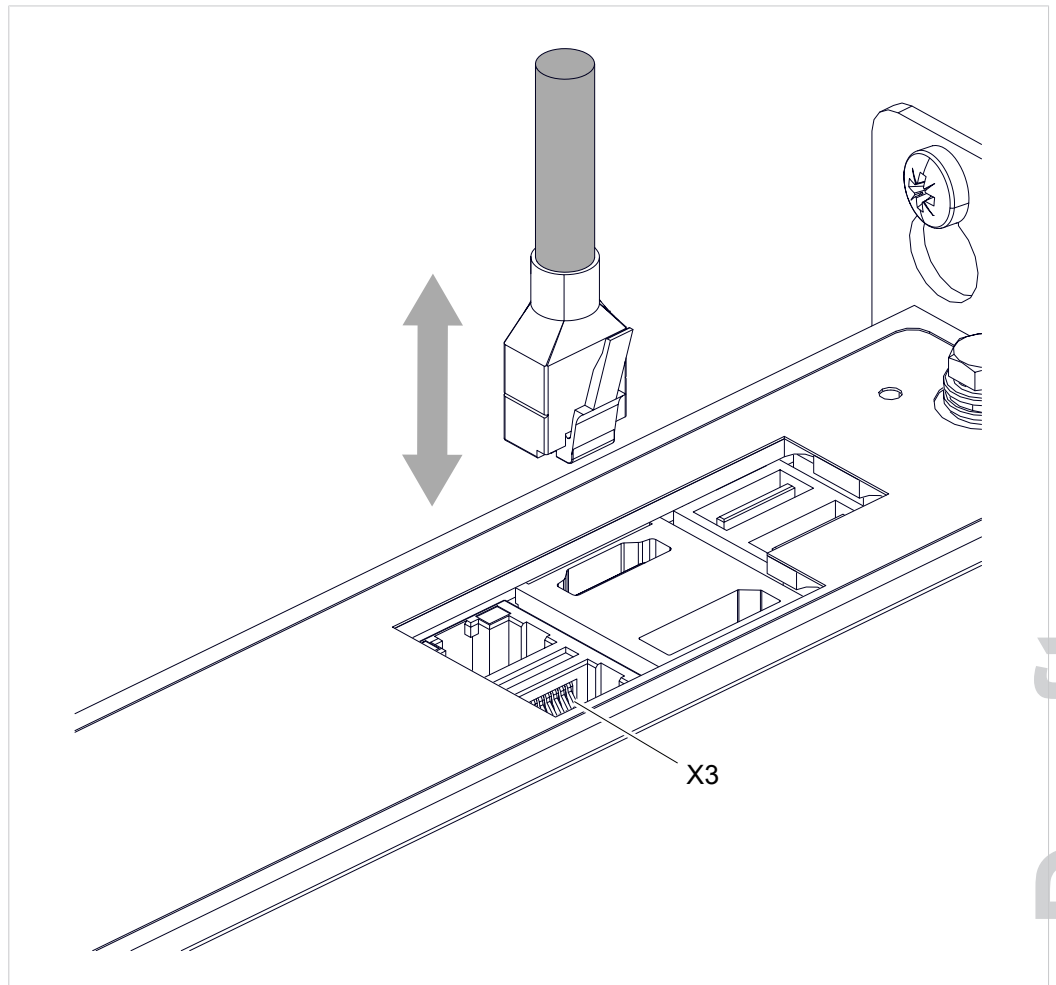

Fig. 4 Connection of customer network

→ Connect the customer network to the X3 interface.

Draft

7 Software

7.1 Parameterizing, Visualizing, Operating

The connected component is parameterized, visualized, documented and operated via the TOX® Software.

See software manual.

7.2 Operating system settings

7.2.1 Post-Installation-Script

All necessary configurations on the operating system are to be made via the Post-Installation-Script.

The Post-Installation-Script is accessible via:

- Via basic settings in the TOX® Software button **Settings** (see [Basic settings screen, Page 40](#))
- Reboot and press button **ESC** during the countdown.

Call up the Post-Install-Script via ESC

- ✓ The keyboard is connected.
1. Restart the TOX® UDI Panel
 2. Press button <ESC> during the countdown.
 3. Select entry "TOX (without write-protection)".
 4. Press button <Enter>.
- ▶ Post-Installation-Script opens.

7.2.2 Operating system settings

Time

In this menu the following settings can be made for the system time:

Entry	Meaning
Zone	Setting the time zone.
Time	Setting the current time.
Date	Selection of the current date.
NTP	Configuring NTP server When the NTP function is activated, the time and date are updated automatically so that it is no longer necessary to set the time and date manually.
Quit	The menu is exited.

Setting the time zone

- ✓ The user is logged in with a suitable user level. The necessary write permissions are available.
1. Tap on **Zone** entry.
 2. Tap on the **Select** button.
 3. Tap on the country in which the time zone is located.
 4. Tap on the **Select** button.
 5. Entry of the city in which the time zone is located.
 6. Tap on the **Select** button.
 7. Confirm the inquiry with the "Yes" button.
 8. Confirm with the **OK** button.
- ▶ The time zone is stored.

Setting the time

- ✓ The user is logged in with a suitable user level. The necessary write permissions are available.
1. Tap on the **Time** entry.
 2. Tap on the **Select** button.
 3. Tap on the **Set the time** input field.
 4. Enter the time (in format HH:MM:SS) and confirm with the **OK** button.
 5. Confirm with the **OK** button.
- ▶ The time is stored.

Draft

Setting the date

- ✓ The user is logged in with a suitable user level. The necessary write permissions are available.
1. Tap on the **Date** entry.
 2. Tap on the **Select** button.
 3. Select the current date in the calendar.
 4. Tap on **OK** button.
 5. Confirm with the **OK** button.
- ▶ The date is stored.

Configuring NTP server

Entry	Meaning
Enable	Activates the function.
Disable	Deactivates the function.
Server	Enter the first NTP server with which the computer should synchronize.
Fallback	Enter the second NTP server with which the computer should synchronize.
RootDistanceMaxSec	Time period for which the system waits until the first NTP server responds. If the first NTP server does not respond, the second NTP server is requested.
PollIntervallMinSec	The minimum polling interval for NTP messages.
PollIntervallMaxSec	The maximum polling interval for NTP messages.
Quit	The menu is exited.

Changing value

- ✓ The user is logged in with a suitable user level. The necessary write permissions are available.
1. Tap on the input field.
 2. Enter the value and confirm with the ↵ button.

Draft

Assign host name

If more than one TOX® UDI Panel is used in the network, it is recommendable to assign a unique name for each device.

Factory setting: tox_hmi3

- ✓ The user is logged in with a suitable user level. The necessary write permissions are available.
- 1. Tap on input field **Enter new host name**.
 - ▷ The alphanumeric keyboard opens.
- 2. Enter device name and press the **OK** button to confirm.
- 3. Tap on **Save** button to save the values.

Reset network

In menu "Reset-network" the network settings can be reset to the factory setting.

- Tap on the **Save** button to save the change and confirm the request with **Yes**.

Draft

Network

In the "Network" menu, the Ethernet IP address can be configured.

Interface	Meaning
Machine_net	Connection for control system (SCC) of TOX® PRESSOTECHNIK
DHCP-xxxx	Connection for customer's network



Under Linux every interface must be located in a different network.

If two interfaces are located in the same network, it is not certain which interface is used for the transfer of the data traffic, and the computer accepts the data traffic for both IP addresses on both interfaces.

The reason is that the IP address under Linux belongs to the host and is not bound to the interface.

Example:

The Machine_net interface has the IP address 192.168.50.111 / subnet mask 255.255.255.0, that is why the interface DHCP-xxxx **can** have the IP address 192.168.0.100 / subnet mask 255.255.255.0, but **not** the IP address 192.168.50.100 / subnet mask 255.255.255.0.

Defining IP Address by entering a Value

- ✓ The user is logged in with a suitable user level. The necessary write permissions are available.
1. Mark entry machine_net or DHCP-xxx and press the **Toothed wheel** button.
 2. Press tab **IPv4 Settings**.
 3. Select entry **Manual** in the selection field.
 4. Press button **Add**.
 5. Enter IP address, network mask and Gateway.
 6. Press button **Save**.
- ▶ The changes are applied.

Draft

Keyboard

The country settings of the keyboard can be changed in menu "Keyboard".

Two keyboard layouts are available for selection:

- German keyboard layout (quertz)
- US international keyboard layout (qwerty)

Changing keyboard layout

- ✓ The user is logged in with a suitable user level. The necessary write permissions are available.
- ✓ The **Keyboard layout** menu is opened.

1. Select keyboard layout.
 2. Press button **Select**.
- ▶ The keyboard layout is changed.

Display

The alignment of the touch screen can be changed in menu "Display".

- ✓ The user is logged in with a suitable user level. The necessary write permissions are available.
1. Tap on Alignment and confirm with **OK**.
 2. Select entry Save and confirm with the **OK** button.
- ▶ The alignment of the screen is saved.

Brightness

The brightness of the touch screen can be changed in menu "Brightness". Also the time can be set when the touch screen is to be dimmed or switched off. This is a substitute for the screen saver.

Timings

Changing value

- ✓ The user is logged in with a suitable user level. The necessary write permissions are available.
- 1. Tap on the input field.
 - ▷ The numerical keyboard opens.
- 2. Enter the value and confirm with the ↵ button.

Brightness on / Brightness dimmed / Brightness off

- ✓ The user is logged in with a suitable user level. The necessary write permissions are available.
- ➔ Select the value of the brightness and confirm with the **OK** button.
- ▶ The brightness of the touch screen is saved.

Quit

The menu is exited.

Draft

VNC

A password for a remote connection to the desktop can be entered in menu "VNC".

Change password

- ✓ The user is logged in with a suitable user level. The necessary write permissions are available.
 - ✓ Menu **Enter VNC password** is opened.
1. Tap on input field **Password**.
 - ▷ Enter password
 2. Tap on the **Repeat** input field.
 - ▷ Re-enter the password.
 3. Tap on **OK** button.

Draft

SSH

An ssh key can be imported in menu "SSH".

To guarantee secure communication we recommend to use an own ssh key.



ssh keys must only be changed by instructed/authorized personnel.

Knowledge about handling keys is assumed.

Auto

An available ssh key (if_rsa) is searched for on a connected removable media.

Manual

Opens a file explorer to import the ssh key.

Remove

The ssh key stored at the factory is removed.

Quit

The menu is exited.

Backup restore

In menu "Backup restore" all settings of the TOX® UDI Panel can be stored on a storage medium (e.g. USB stick) and restored again.

Ubiquity

The TOX® UDI Panel can be remote controlled with the aid of the Ubiquity software.

The TOX® PRESSOTECHNIK cannot establish a connection to the remote maintenance of the TOX® UDI Panel independently.

The process to the connection of the remote maintenance must be made from the customer.

Reset identity

This menu may only be used after prior consultation with TOX® PRESSOTECHNIK.

Backup Identity

The access data are saved on the TOX® UDI Panel.

Restore Identity

An existing backup of the access data are replayed on the TOX® UDI Panel.

- ✓ The user is logged in with a suitable user level. The necessary write permissions are available.
- ✓ The backup file `ubiquity-identity-backup.tgz` is available and stored in directory `/home/tox/toxsoftware`.

1. Select **Restore identity**.
 2. Press button **Select**.
- ▶ The access data are restored again.

Test

Checks whether a connection can be established to the remote maintenance (e.g. whether the Internet connection is active).

Connect

- ✓ The user is logged in with a suitable user level. The necessary write permissions are available.
- ✓ First initialization is carried out (see [First initialization, Page 41](#)).
- ✓ The **Ubiquity** menu is opened.

1. Select entry **Connect**.
 2. Press button **Select**.
- ▶ The connection is established.

Disconnect

The existing connection for the remote maintenance is closed.

Status

The current status of the remote maintenance is displayed.

Quit

The menu is exited.

Maintenance stick

In menu "Maintenance stick" a storage medium (e.g. USB stick) is prepared for the use of the WinSCP protocol for the transmission of data.

Creating maintenance stick

- ✓ The user is logged in with a suitable user level. The necessary write permissions are available.
 - ✓ Menu **Maintenance stick** is opened.
 - ✓ USB stick is inserted in the TOX® UDI Panel.
1. Select USB stick and press button **Select**.
 2. Follow the instructions on the screen.
- ▶ All necessary files are copied to the USB stick.

Advanced

The following menus may only be changed after prior consultation with TOX® PRESSOTECHNIK.

- Test all tests
- Test touch and display
- Test memory and temperature
- SSD
- OS-Update-Stick
- Repair HMI folder rights
- Services
- DPI
- Resolution
- Session
- Switch UDI-Detection
- APT-Sources
- Password

Quit

The menu is exited.

Quit

Menu "Settings" is exited.

Draft

7.3 Operation as UDI panel / UDI module

The TOX® Software is carried directly on the TOX® UDI Panel.

7.3.1 Basic settings screen

The "Basic settings" screen appears when the entry "Basic settings" is selected in the main menu under **Settings**.

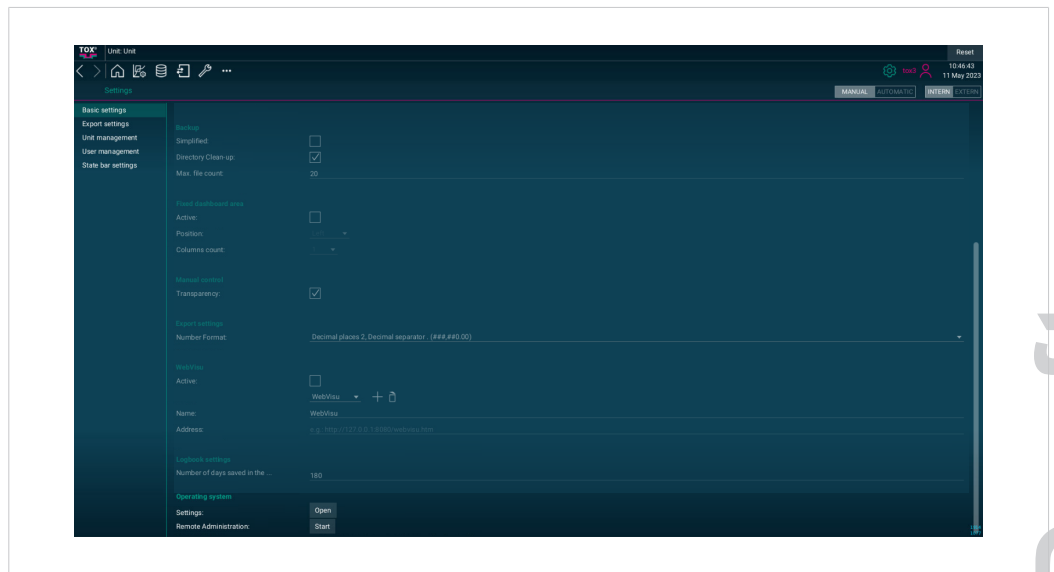

Draft

Fig. 5 Basic settings screen

	Button	Function
	Settings	Opens the settings menu of the operating system after the restart of the TOX® UDI Panel (see Operating system settings, Page 29).
	Remote maintenance	Starts the remote maintenance function.

7.3.2 Remote maintenance (option)

First initialization

For this option a licence from TOX® PRESSOTECHNIK is required.

To be able to use the remote maintenance it needs to be set up once prior to its first use.

- ✓ Menu **Operating system setting** is open (see [Operating system settings, Page 29](#)).
- ✓ TOX® UDI Panel has Internet access.
- ✓ The user is logged in with a suitable user level. The necessary write permissions are available.

1. Select entry **Ubiquity**.
2. Press button **Select**.
3. Select entry **Connect**.
4. Press button **Select**.
5. Now transmit the entries displayed in fields "ID" and "Password" to TOX® PRESSOTECHNIK.
 - ▷ These two entries are required once to establish a connection to the TOX® UDI Panel.
6. If the connection has been established successfully, press button **Backup identity**.
 - ▷ The access data are saved saved on the TOX® UDI Panel.



Backup of access data

TOX® PRESSOTECHNIK recommends to also save the previously created backup file (ubiquity-identity-backup.zip) outside the TOX® UDI Panel with the aid of the maintenance stick.

Draft

Establishing connection

The TOX® UDI Panel can be remote controlled with the aid of the Ubiquity software.

The TOX® PRESSOTECHNIK cannot establish a connection to the remote maintenance of the TOX® UDI Panel independently.

The process to the connection of the remote maintenance must be made from the customer.

1. Open the basic settings menu in the TOX® Software, (see [Basic settings screen, Page 40](#)).
2. Press the remote maintenance **Start** button.

▶ The connection to the remote maintenance is established.

- OR -

As alternative, a connection to remote maintenance can also be established via the **Connect** button in menu **Ubiquity** (see [Ubiquity, Page 36](#)).

Draft

7.3.3 Establishing VNC connection

Via the VNC protocol, remote computers can be controlled in a network according to the server-client principle with the transmission of mouse and keyboard entries.

If, for example, the 10.172.227.115 is used for the TOX® UDI Panel as fixed IP address, a remote access via VNC and

`http://10.172.227.115:6080/vnc.html?autoconnect=true&password=tox&reconnect=true&reconnect_delay=5000&resize=scale`

can be established.

Establishing connection

- ✓ IP address of the TOX® UDI Panel is known.
- 1. Open the web browser.
- 2. Enter the address according to the above-mentioned concept.
- ▶ Connection to the TOX® UDI Panel is being made.

Draft

8 Maintenance

8.1 Requirements for maintenance and cleaning

-  Clean and check the product regularly with regard to material, use and degree of contamination.

Suitable cleaning agents are to be used for cleaning:

- Do not use aggressive, and solvent-containing cleaner.
The layer can harden and/or the glued cover can come loose.
- Use cleaning set, such as industrial cleaner (e.g. Loctite 7063, or Würth Montagekraftreiniger 0890 107), vacuum cleaner, dry cloth and brush.

8.2 Update TOX® Software

Since for a VNC connection with a TOX® UDI Panel the USB connection is not passed on, there is no possibility here to perform a software update via the VNC connection on the displayed target device.

There are several options to update the TOX® Software:



Option 1

- ✓ TOX® Software is finished.
- ✓ Maintenance stick is created (see [Maintenance stick, Page 38](#)).
- ✓ Software package and documentation can be downloaded from the data exchange portal or a data carrier is available.
- ✓ Necessary authorizations are available.
- ✓ PC and TOX® UDI Panel must be located in the same network.

1. Open the maintenance stick.
2. Start program "Tox-Linux-Filetransfer.exe".
 - ▷ A window similar to Windows®-Explorer opens.
 - ▷ In the left window you are located on the local computer, in the right window on the TOX® UDI Panel.
3. Copy the installation file on drive "toxsoftware/transfer".
4. Log in with user "worker".
 - ▷ The TOX® Software will then be updated after an enquiry.

Draft

Option 2
(from Image Version 2.0.9 and TOX® Software xxx.23.009)

	Display/control panel	Function
	Software information	Opens the software information menu.
	Information	Displays information.

- ✓ Software package and documentation can be downloaded from the data exchange portal or a data carrier is available.
 - ✓ Necessary authorizations are available.
1. Copy update package to the USB stick.
 2. Connect USB stick to device.
 3. Tap on TOX logo.
 4. Tap on **Information** button.
 5. Tap on **Update** button.
 6. Tap on button under change media.
 7. Select the TOX® Software update file and tap on the **Open** button.
 8. Follow the instructions on the screen.

Draft

9 Disassembly and Disposal

9.1 Disposal



When disposing of packaging, consumables and spare parts, including the machine and its accessories, the relevant national environmental protection regulations must be complied with.



For the environmentally compatible utilization and disposal of its electronic components, please contact the certified disposal company for electronic waste or return it to TOX® PRESSOTECHNIK.

For further information about the take-back and forms see www.tox.com in the service sector.

Regarding questions about disposal please contact TOX® PRESSOTECHNIK GmbH & Co. KG (see [Contact and source of supply, Page 9](#)).

Draft

10 Appendices

10.1 Declaration of conformity

Draft



EU DECLARATION OF CONFORMITY

Original EU declaration of conformity

The manufacturer TOX® PRESSOTECHNIK GmbH & Co. KG declares herewith that the following product

Designation / function	Device for visualization processing without display
Product name / module	TOX®UDI Module
Models / types	TOX®UDI 100-00
Serial number	see type plate
Description	The TOX® UDI Module is a built-in device for processing and forwarding signals to a higher-level display

complies with all relevant provisions of the following legislation, including any changes in force at the moment of the declaration.

This declaration of conformity is issued under the sole responsibility of the manufacturer.

Applied EU legislation:

2014/30/EU	EMC Directive, OJ L 96 dated 29/3/2014, P. 79–106
2011/65/EU	RoHS Directive, OJ. L 174 dated 1.7.2011, P. 88–110

Source references of the applied harmonized standards:

DIN EN 61000-6-2:2019-11	Electromagnetic compatibility (EMC) - Part 6-2: Generic standards - Immunity standard for industrial environments (IEC 61000-6-2:2016)
DIN EN 61000-6-4:2020-09	Electromagnetic compatibility (EMC) - Part 6-4: Generic standards - Emission standard for industrial environments (IEC 61000-6-4:2018)
DIN EN IEC 63000:2019-05	Technical documentation for assessing electric and electronic devices with regard to the limitation of hazardous substances (IEC 63000:2016)

Place and date Weingarten, 10.06.2024

Signature

Information on the signatory

ppa Elmar Locher
Head of Key Account Management



UK DECLARATION OF CONFORMITY

Original declaration of conformity

The manufacturer TOX® PRESSOTECHNIK GmbH & Co. KG declares herewith that the following product

Designation / function	Device for visualization processing without display
Product name / module	TOX® UDI Module
Models / types	TOX® UDI 100-00
Serial number	see type plate
Description	The TOX® UDI Module is a built-in device for processing and forwarding signals to a higher-level display.

complies with all relevant provisions of the following enactments and their amendments.

This declaration of conformity is issued under the sole responsibility of the manufacturer.

Applied enactments:

SI 2016/1091	Electromagnetic Compatibility Regulations 2016
SI 2012/3032	The Restriction of the Use of Certain Hazardous Substances in Electrical and Electronic Equipment Regulations 2012

Reference to the used designated standards:

DIN EN 61000-6-2:2019-11	Electromagnetic compatibility (EMC) - Part 6-2: Generic standards - Immunity standard for industrial environments (IEC 61000-6-2:2016)
DIN EN 61000-6-4:2020-09	Electromagnetic compatibility (EMC) - Part 6-4: Generic standards - Emission standard for industrial environments (IEC 61000-6-4:2018)
DIN EN IEC 63000:2019-05	Technical documentation for the assessment of electrical and electronic products with respect to the restriction of hazardous substances (IEC 63000:2016)

Place and date Weingarten, 10.06.2024

Signature

Information on the signatory



ppa Elmar Locher
Head of Key Account Management

Index

B		E	
Backup restore	36	Establishing connection	
Basic safety requirements	10	Remote maintenance	42
Basic settings		Exclusion of liability.....	5
Screen	40	F	
Brightness	34	First initialization	
C		Remote maintenance	41
Configuration		Function description.....	15
Backup restore.....	36	G	
Brightness	34	Gender note.....	6
Display	33	Grounding	
Host name	31	Connection	23
Keyboard	33	Guidelines	5
Maintenance stick	38	H	
Network.....	32	Hazard	
Quit	39	Electrical.....	12
Reset network.....	31	Hazard potential.....	12
SSH	36	Host name	
Time.....	29	Assign	31
Ubiquity	36	I	
VNC	35	Images	
Conformity	5	Highlighting	8
Connecting line		Important information.....	5
Technical data	17	Information	
Connection		Important	5
Grounding	23	Installation.....	19
TOX® UDI modules	25	Installation spacings.....	20
Connections	17	Requirement.....	20
Contact	9	Safety	19
D		Set-up location	20
Declaration of conformity.....	47	TOX® UDI modules	22
Disassembly	46	Installation spacings	
Dispatch		Installation	20
Repair	18	Intended use	14
Display.....	33	K	
Disposal.....	46	Keyboard.....	33
Document			
additional	6		
Validity	6		

L

LABS 15
 Legal note..... 5

M

Maintenance 44
 Maintenance stick..... 38
 Measures
 Organizational..... 10
 Misuse 14

N

Network 32
 Note
 Gender 6
 General 8
 Legal 5
 Warning signs 7

O

Operating system
 Post-Installation-Script..... 28
 Settings..... 28, 29
 Operation
 Safe 14
 UDI panel / UDI module 40
 Organizational measures 10

P

Post-Installation-Script
 Operating system..... 28
 Product overview 15

Q

Qualifications 11
 Quit..... 39

R

Remote maintenance
 Establishing connection 42
 First initialization..... 41
 Remote maintenance (option) 41
 Repair
 Dispatch 18
 Requirement
 Installation 20
 Reset network 31

S

Safety 10
 Installation 19
 Safety requirements
 Basic 10
 Operating company 10
 Screen
 Basic settings 40
 Selection
 Personnel 11
 Selection of personnel 11
 Settings
 Operating system 28, 29
 Set-up location 20
 Software 28
 Source of supply 9
 SSH..... 36
 Storage 18
 Temporary storages 18
 Substances harmful to the wetting properties of
 lacquers (LABS) 15
 Supply voltage 17

T

Target group	6
Technical data	17
Connecting line	17
Connections	17
Supply voltage	17
Texts	
Highlighting	8
Time.....	29
TOX® Software	
Update	44
TOX® UDI modules	
Connection.....	25
Installation.....	22
Transport	18
types of risks	
Special	13

U

Ubiquity	
Configure	36
UDI panel / UDI module	
Operation	40
Update	
TOX® Software.....	44
Use	
Intended	14

V

Validity	
Document	6
VNC	35
VNC connection	
Establishing	43

W

Warning signs.....	7
--------------------	---